

Slides for air nippers actuators

- Sliding nippers (with multiple cut action for harder to cut sprues) can be assembled.
- Available in two sizes: bore 16 and 25 mm.
- Spring open (NO), or spring closed (NC).
- With (S versions), or without sensor slots.
- Optional magnetic sensors 1.
- Adjustable stroke (maximum 10mm).

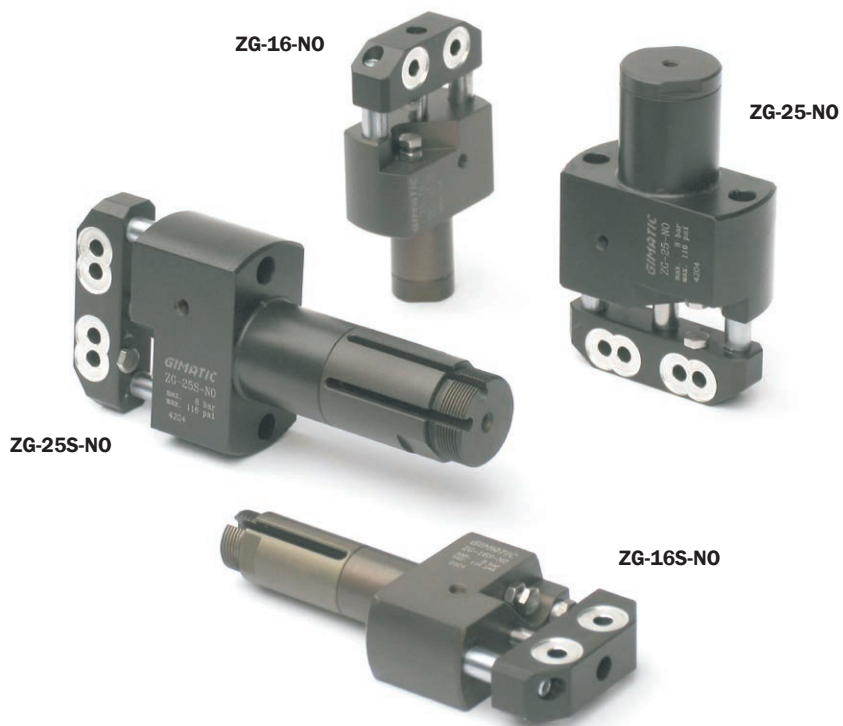

	ZG-16-NO ZG-16S-NO	ZG-16-NC ZG-16S-NC	ZG-25-NO ZG-25S-NO	ZG-25-NC ZG-25S-NC
Medium	Filtered, lubricated / non lubricated compressed air			
Pressure range	3 ÷ 8 bar			
Temperature range	5° ÷ 60 °C			
Stroke	10 mm	10 mm	10 mm	10 mm
Piston bore	Ø16 mm	Ø16 mm	Ø25 mm	Ø25 mm
Retraction force at 6 bar	65 N	120 N	210 N	275 N
Extension force at 6 bar	135 N	80 N	300 N	240 N
Retraction force at 0 bar	0 N	25 N	0 N	30 N
Extension force at 0 bar	25 N	0 N	30 N	0 N
Cycle air consumption	5.6 cm ³	5.6 cm ³	21 cm ³	21 cm ³
Weight without air nipper	ZG-... ZG-...S-...	180 g 200 g	180 g 200 g	360 g 425 g

Dimensions (mm)

- ① Sensor groove
- ② Air connection M5
- ③ Air connection M5
- ④ Adjustable stroke 0÷10 mm

	ZG-16...	ZG-16S...	ZG-25...	ZG-25S...
A	29	-	36	-
B	-	63	-	78.5
C	10 max	10 max	10 max	10 max
D	Ø20	Ø20	Ø30	Ø30
E	-	8	-	11
F	17	17	19	19
G	6	6	12.5	12.5
H	20.5	20.5	20.5	20.5
J	-	-	35	35
K	31	31	38	38
L	50	50	65	65
M	-	M17x1	-	M27x1
N	Ø50	Ø50	Ø65	Ø65
P	18	18	18	18
Q	25	25	32	32
R	59.5	59.5	66.5	66.5
S	-	80°	-	60°
T	Ø5.1	Ø5.1	Ø5.1	Ø5.1
V	15	15	15	15
W	17	17	27	27
Y	52	52	59	59

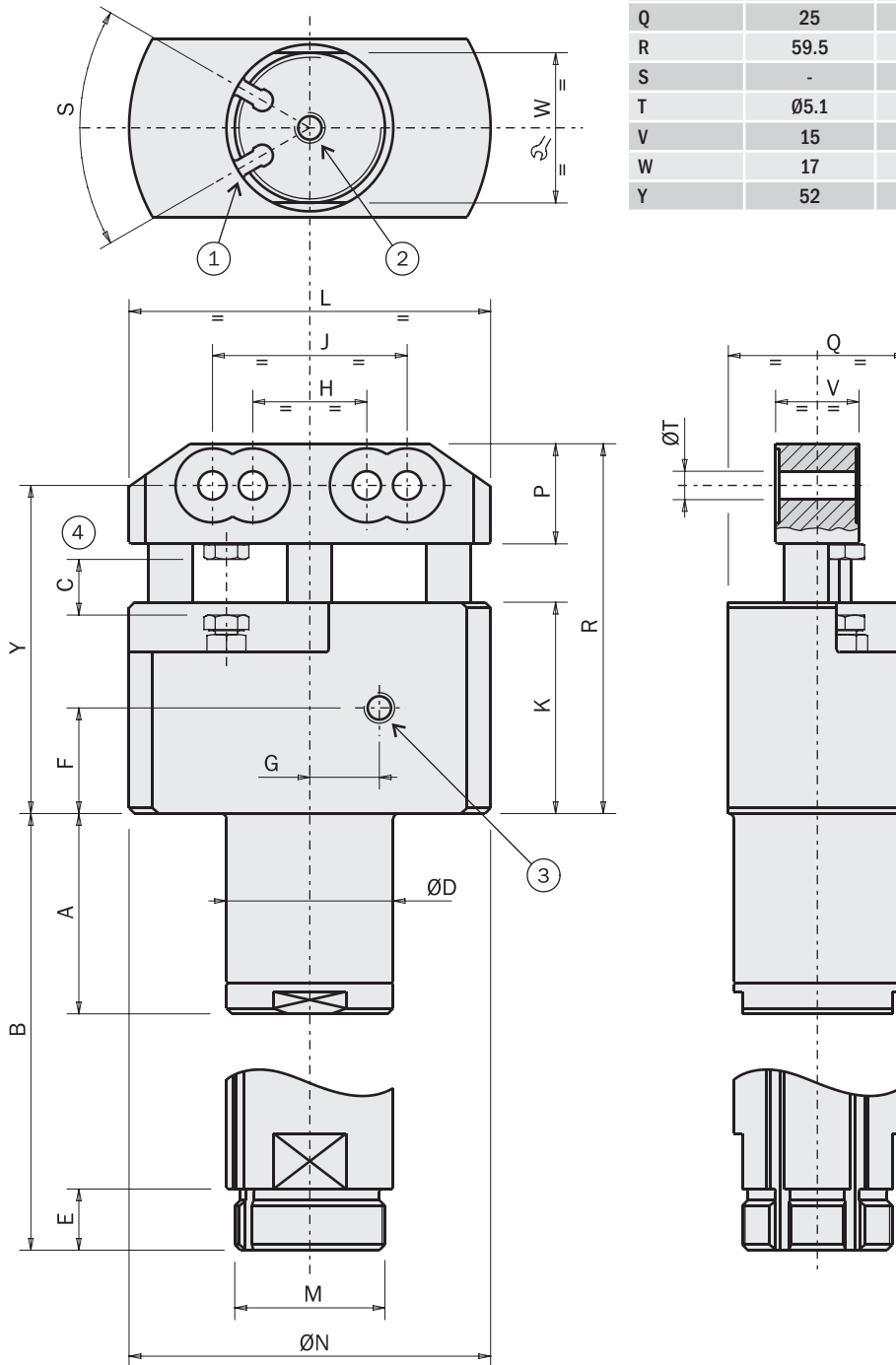

FIRST ANGLE PROJECTION