

**2-jaw self-centering angular mini gripper, series TFA**

- Single acting with spring opening.
- Several mounting accessories.
- Optional suspension kit (1).



	TFA10-25	TFA14-25	TFA20-25 TFA20-25S
Medium	Filtered, lubricated / non lubricated compressed air		
Pressure range	2.5 ÷ 8 bar		
Temperature range	5 ÷ 60 °C.		
Stroke	2 x 12.5°		
Closing torque at 6 bar each jaw	17 Ncm	48 Ncm	215 Ncm
Total closing torque at 6 bar	34 Ncm	96 Ncm	430 Ncm
Opening torque at 0 bar each jaw	0.5 Ncm	0.8 Ncm	1.3 Ncm
Total opening torque at 0 bar	1 Ncm	1.6 Ncm	2.6 Ncm
Maximum working frequency	2 Hz	2 Hz	2 Hz
Cycle air consumption	0.2 cm <sup>3</sup>	0.5 cm <sup>3</sup>	2 cm <sup>3</sup>
Weight	12 g	30 g	95 g (TFA20-25) 120 g (TFA20-25S)

(1)

Suspension code	TFA10SP05	TFA14SP05	TFA20SP10
Weight	10 g	35 g	85 g

Dimensions (mm)

TFA10-25

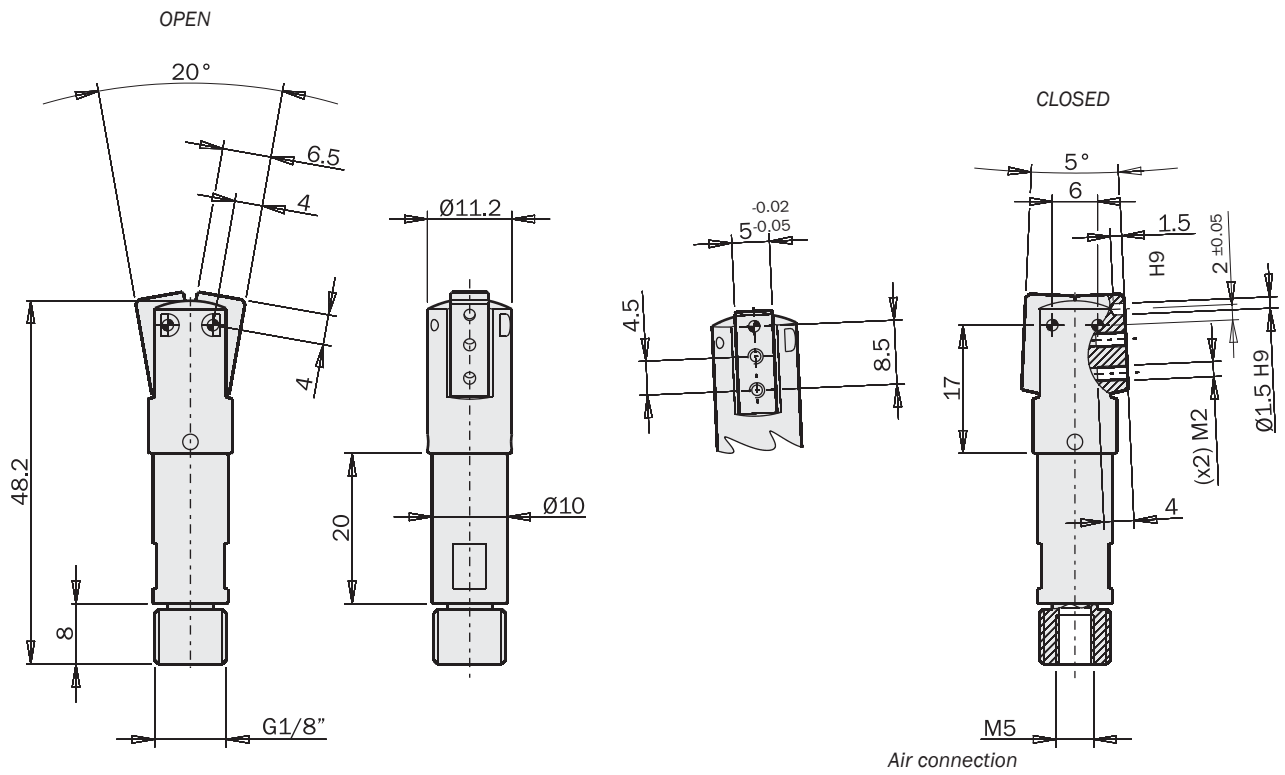

Gripper +  
Suspension

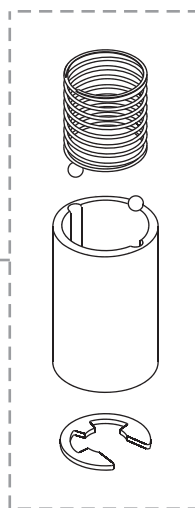
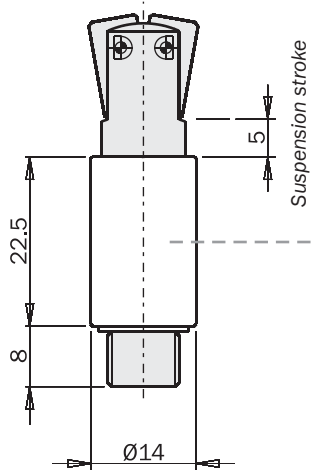

TFA10SP05

Optional suspension kit



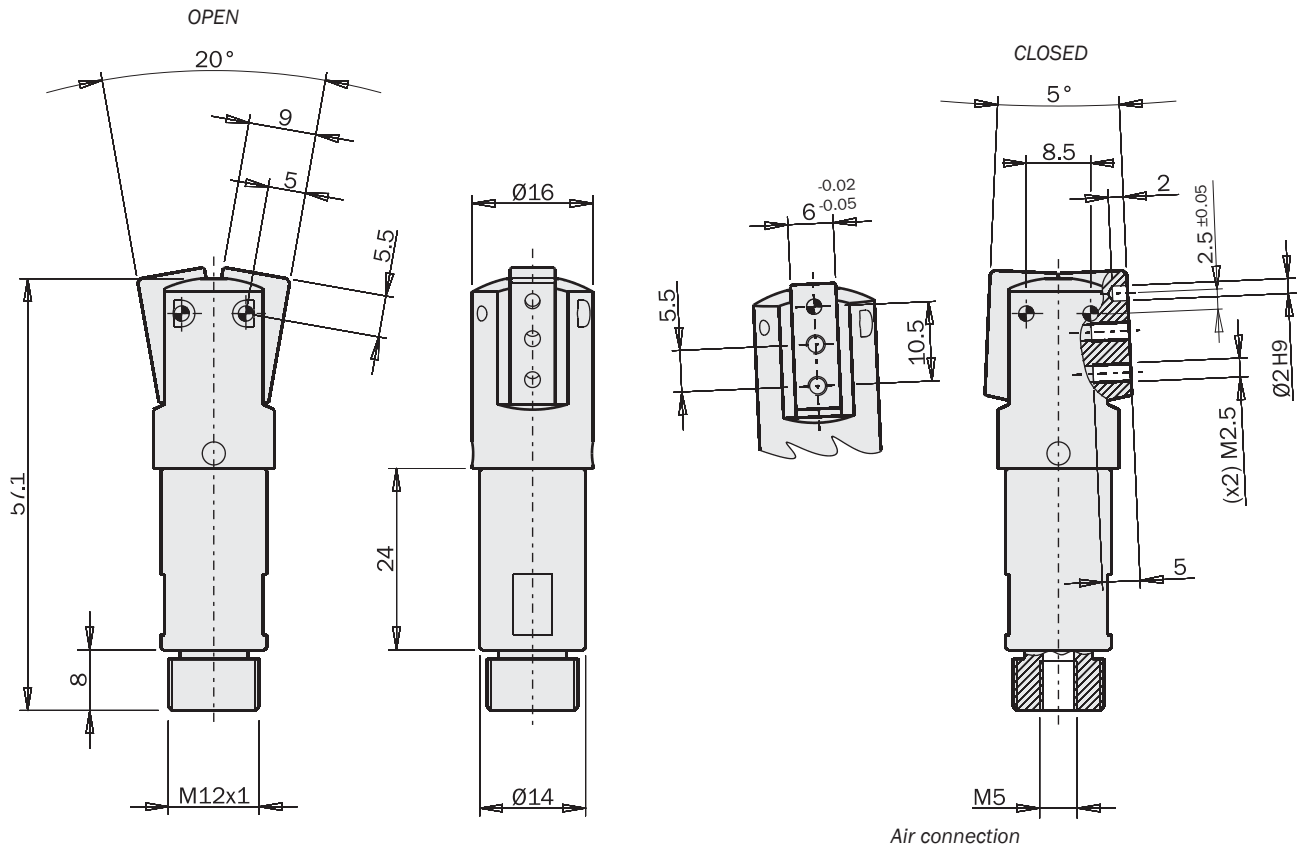

Gripper + Suspension

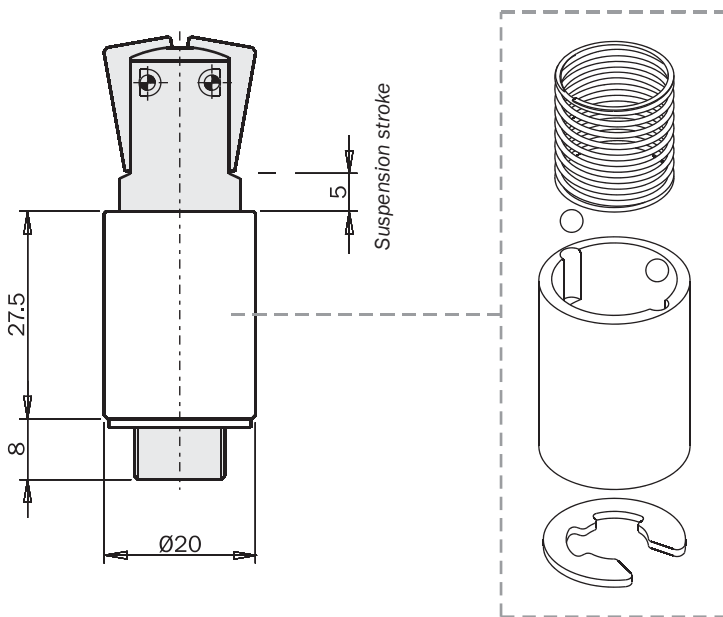

TFA14SP05  
Optional suspension kit

Dimensions (mm)

TFA20-25  
TFA20-25S

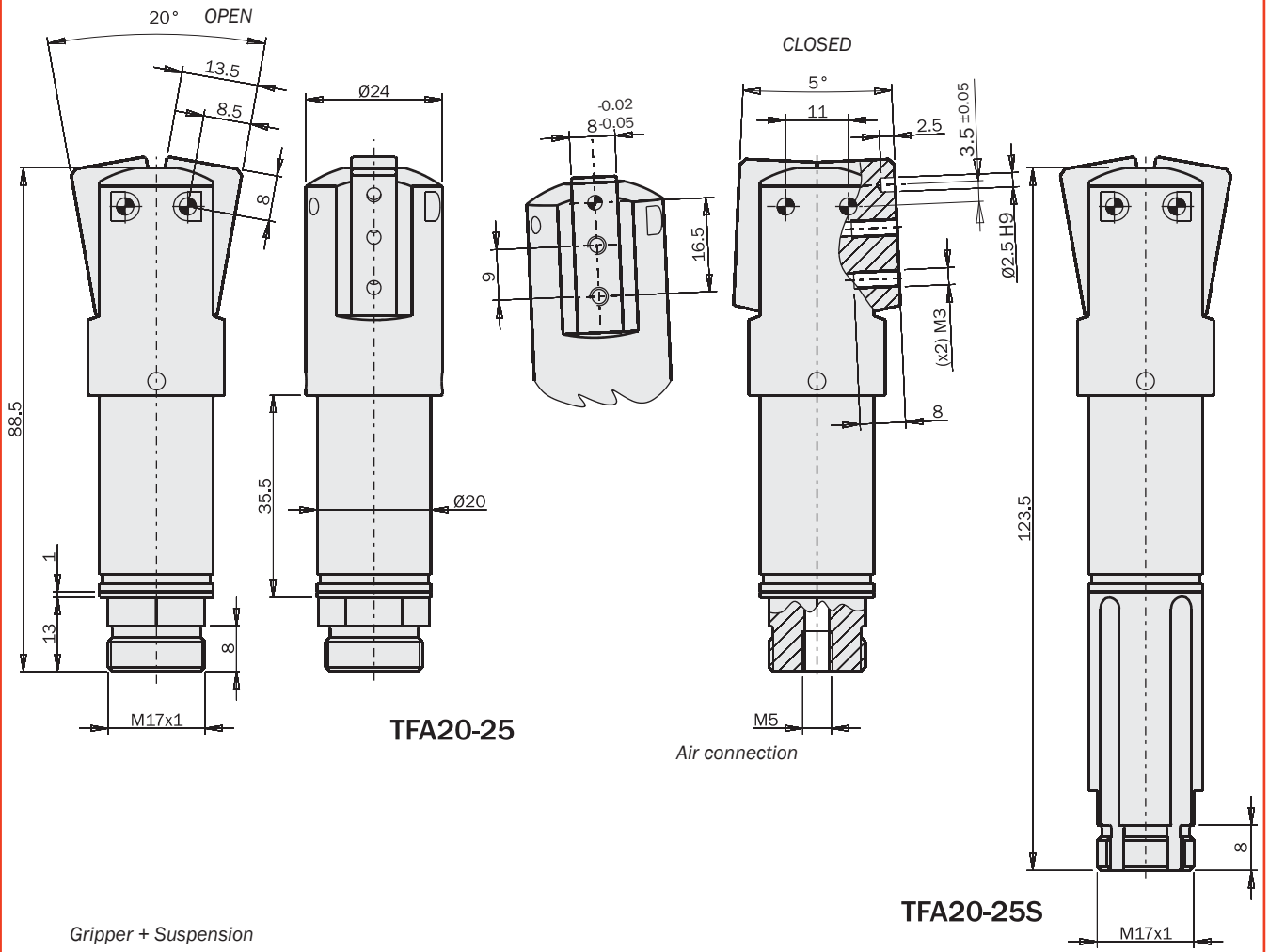

Gripper + Suspension

TFA20-25S

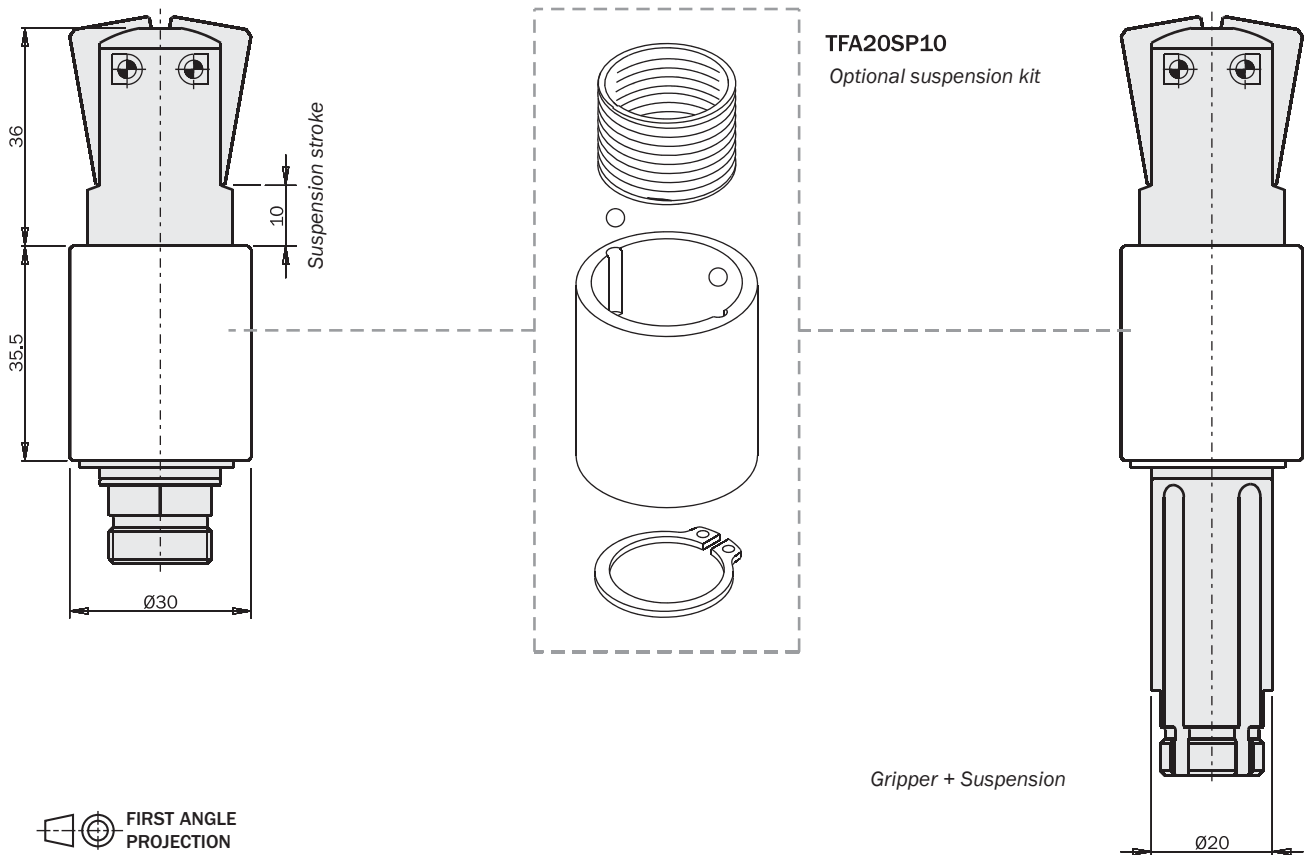

TFA20SP10  
Optional suspension kit

Gripper + Suspension